

Design Gabriele e Oscar Buratti



Otab, 883/T
tavolo \ table

Otab è una proposta che gioca sulle proporzioni: al volume imponente della base fa da contrappunto l'essenzialità del piano. Un monolite materico che nasce dall'accostamento di due forme pure e geometriche: il cerchio e il cilindro. Il prezioso dettaglio in ottone brunito alla base del tavolo ne sottolinea le linee aggraziate e il profilo sinuoso.

Otab is a proposal that plays on proportions: the imposing volume of the base is counterpointed by the essentiality of the top. A material monolith that arises from the combination of two pure and geometric shapes: the circle and the cylinder. The precious bronzed brass detail at the table's base underlines its graceful lines and sinuous profile.

Informazioni tecniche \ Technical information

Descrizione tecnica \ Technical description

Tavolo tondo con piano circolare e base cilindrica centrale in frassino e dettaglio in ottone brunito. Piano in frassino impiallacciato impiallacciato con bordi massellati. Accessorio abbinato: piatto centrale girevole lazy susan in marmo.

Circular table with central cylindrical base in ash wood and detail in bronzed brass. Top in veneered ash wood and solid wood edges. Matching accessory: lazy susan central rotating plate in marble.

Dimensioni \ Dimensions

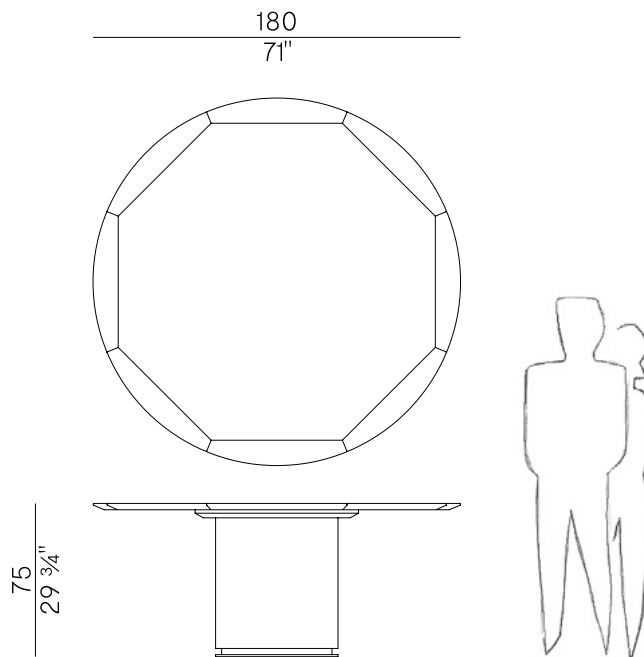

Imballaggio \ Packaging



PACKAGING - Ø 180

2 box = m³ 1,33

gross weight - Kg 137

Finiture \ Finishes

Finiture base e piano\
Base and top finishes

Frassino \ Ash 



SG
Beige \
Beige



SC
Biscotto \
Biscuit



HJ
Moka \
Moka



HK
Grigio plumbeo \
Dark grey



HL
Wengé \
Wengé

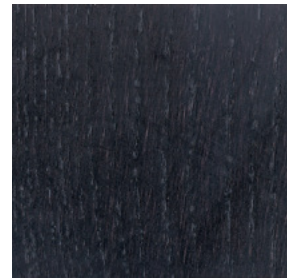

HP
Carbone \
Carbon

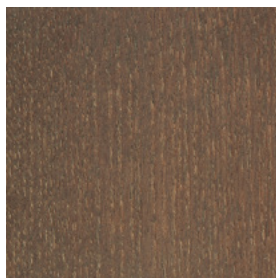

SN
Noce \
Walnut

Finiture \ Finishes

Dettagli finiture base \
Base accents

Metallo \ Metal 



Ottone brunito \
Bronzed brass

Design Gabriele e Oscar Buratti



Otab, 883/T
tavolo \ table

Otab è una proposta che gioca sulle proporzioni: al volume imponente della base fa da contrappunto l'essenzialità del piano. Un monolite materico che nasce dall'accostamento di due forme pure e geometriche: il cerchio e il cilindro. Il prezioso dettaglio in ottone brunito alla base del tavolo ne sottolinea le linee aggraziate e il profilo sinuoso.

Otab is a proposal that plays on proportions: the imposing volume of the base is counterpointed by the essentiality of the top. A material monolith that arises from the combination of two pure and geometric shapes: the circle and the cylinder. The precious bronzed brass detail at the table's base underlines its graceful lines and sinuous profile.

Informazioni tecniche \ Technical information

Descrizione tecnica \ Technical description

Tavolo tondo con piano circolare e base cilindrica centrale in frassino e dettaglio in ottone brunito. Piano in marmo. Accessorio abbinato: piatto centrale girevole lazy susan in marmo.

Circular table with central cylindrical base in ash wood and detail in bronzed brass. Marble top. Matching accessory: lazy susan central rotating plate in marble.

Dimensioni \ Dimensions

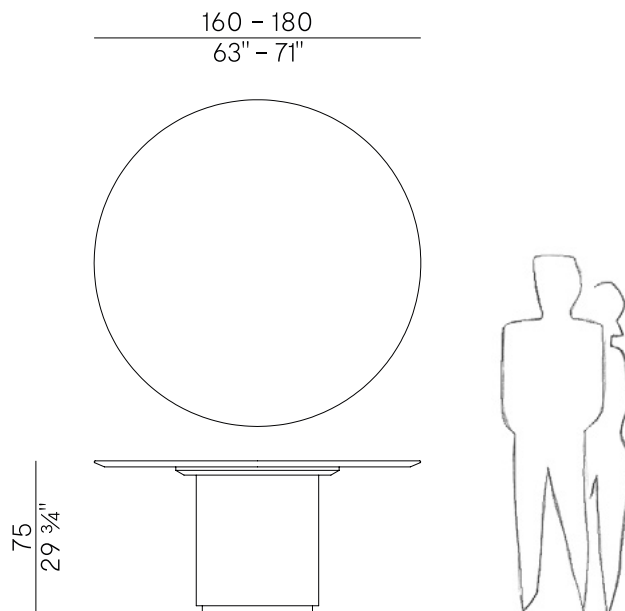

Imballaggio \ Packaging



PACKAGING - Ø 160

2 box = m³ 3.79

gross weight Kg 267



PACKAGING - Ø 180

2 box = m³ 4.04

gross weight Kg 347

Finiture \ Finishes

Finiture base \
Base finishes

Frassino \ Ash 



SG
Beige \
Beige



SC
Biscotto \
Biscuit

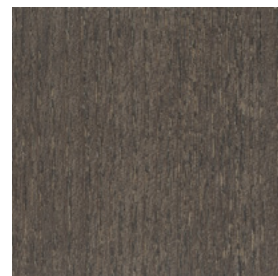

HJ
Moka \
Moka

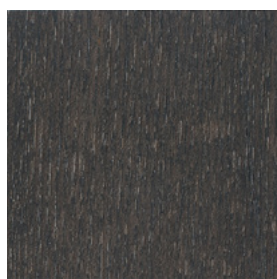

HK
Grigio plumbeo \
Dark grey



HL
Wengé \
Wengé

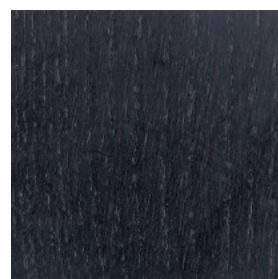

HP
Carbone \
Carbon

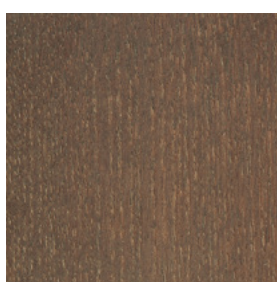

SN
Noce \
Walnut

Finiture \ Finishes

Finiture piano \
Top finishes

Marmo \ Marble 

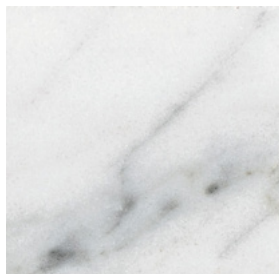

Bianco Carrara opaco \
Matt White Carrara



Bianco Carrara lucido \
Glossy White Carrara

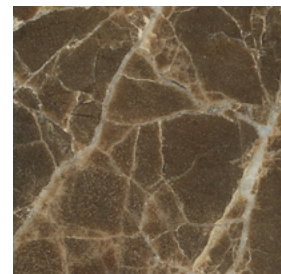

Dark Emperador \
Dark Emperador



Fior di Pesco \
Fior di Pesco

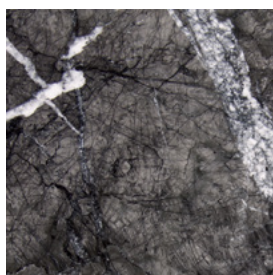

Grigio Carnico \
Grigio Carnico

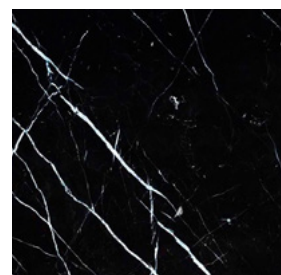

Nero Marquina \
Nero Marquina